

**Three Point Grass Master Mower
Operator Manual
With Parts Listing**

**McKenzie Supply & Equipment Ltd.
1660 20-1/2 Street
Rice Lake WI 54868
715-234-6848
Email : mckequip@chibardun.net
Web Site : www.mckenzieltd.com**

Table Of Contents

| | |
|----------------------------------|------|
| Safety Introduction | 1 |
| Safety Messages | 2-4 |
| Operation Section | 5 |
| Maintenance Section | 6 |
| Parts Section | 7-11 |
| Flail Mower Head Parts Diagram | 7 |
| Flail Mower Head Parts List | 8 |
| Flail Mower Head Parts List | 9 |
| Flail Cutter Shaft Parts Diagram | 10 |
| Flail Cutter Shaft Parts List | 11 |

Safety Introduction

A safe and careful operator is the best operator. Safety is of primary importance to the manufacturer and should be to the owner operator. Most accidents can be avoided by being aware of your equipment, your surroundings, and observing certain precautions. The safety section of this manual includes a list of safety messages that, if followed, will help protect the operator and bystanders from injury or death. Read and understand these safety messages before assembling, operating or servicing this attachment. This equipment should only be operated by those persons who have read the manual, who are responsible and trained, and who know how to do so safely and responsibly.

The safety alert symbol combined with a signal word, as seen below, is used throughout this manual and on decals which are attached to the equipment. The safety and alert symbol means: "**ATTENTION! BECOME ALERT! YOUR SAFETY IS INVOLVED!**" The symbol and signal word are intended to warn the owner / operator of impending hazards and the degree of possible injury faced when operating this equipment.

Practice all usual and customary safe working precautions and above all remember safety is up to YOU! Only YOU can prevent serious injury or death from unsafe practices.

CAUTION!

This symbol designates the lowest level of safety message; **warns of possible injury**. Decals located on the equipment with this signal word are black and yellow.



WARNING!

This symbol warns of **serious injury or possible death!** Decals located on the equipment with this signal word are black and orange



DANGER!

This symbol warns of **imminent death / critical injury!** Decals located on the equipment with this signal word are red and white.



READ, UNDERSTAND, and FOLLOW the following safety messages. Serious injury or death may occur unless care is taken to follow the warnings and instructions stated in the safety messages. Always use common sense to avoid hazards.

Safety

DANGER!



Never operate the mower or tractor until you have read and completely understand this operator manual, and the tractor operator manual, and each of the safety messages found in this manual and on the tractor and mower. Learn how to stop tractor engine suddenly in an emergency. Never allow inexperienced or untrained personnel to operate the tractor and mower without supervision. Make sure operator has fully read and understood the manuals prior to operation.

WARNING!



Always maintain the safety decals in good readable condition. If the decals are missing, damaged, or unreadable, obtain and install replacement decals immediately.

WARNING!



Operate this attachment only on a tractor equipped with an approved roll-over protection system (ROPS). Always wear seat belt. Serious injury or even death could result from falling off power unit, particularly during a roll-over, when operator could be pinned under power unit.

WARNING!



Do not modify or alter this mower. Do not permit anyone to modify or alter this mower, or any of its components or any mower function.

DANGER!



BEFORE leaving the tractor seat, always engage parking brake and turn off the PTO, stop engine, remove key, and wait for all moving parts to stop. Never dismount tractor with the engine running. Operate controls from tractor seat only.

Safety

DANGER! Never allow children or other persons to ride on tractor or mower. Falling off can result in serious injury or death.



DANGER! Never work under the mower, or any lifted component unless the mower is securely supported or blocked up to prevent sudden or inadvertent falling which could result in serious injury or death.



DANGER! Do not operate mower with hydraulic oil leaking. Oil is expensive and its presence could present a hazard. Do not check for leaks with your hand! Use a piece of heavy paper or cardboard. High pressure oil streams from breaks in the line could penetrate the skin and cause tissue damage including gangrene. If oil does penetrate skin, have the injury treated immediately by a physician knowledgeable and skilled in this procedure.



WARNING! The operator and all support personnel should wear hard hats, safety shoes, safety glasses, and proper hearing protection at all times for protection from injury including injury from items thrown by the mower.



WARNING! Periodically inspect all moving parts for wear or damage and replace when necessary with authorized service parts. Look for loose fasteners, worn or broken parts, and leaky or loose fittings. Make sure all pins have cotter pins and washers if required. Serious injury may occur from not properly maintaining this mower in good working order.



DANGER! Extreme care should be taken when operating near loose objects such as gravel, rock, wire, and other debris. Inspect the area before mowing. Foreign objects should be removed from the site to prevent machine damage and / or bodily injury or even death. Any objects that cannot be removed must be clearly marked and carefully avoided by the operator. Stop mowing immediately if blades strike foreign object. Repair all damage and make certain rotor or blade carrier is balanced before resuming mowing.



Safety

DANGER!



All safety shields, guards and safety devices including but not limited to: Deflectors, chain guards, steel guards, and retractable door shields should be used and maintained in good working condition. All safety devices should be carefully inspected at least daily for missing or broken components. Missing, broken, or worn items must be replaced at once to reduce the possibility of injury or death from thrown objects, entanglement, or blade contact.

DANGER!



Never operate mower in raised position. Raising mower off the ground creates possibility of objects being thrown from mower.

DANGER!



Never service mower with tractor engine running. Before performing service work shut off engine, remove key, and make sure mower is securely blocked.

DANGER!



The rotating parts of this mower have been designed and tested for rugged use. However, the blades could flail upon impact with heavy, solid objects such as metal guards rails and concrete structures. Such impact could cause the broken object to be thrown outward at very high velocities. To reduce the possibility of property damage serious injury, or even death, never allow the cutting blades to contact such obstacles.

DANGER!



NEVER use drugs or alcohol immediately before or while operating the tractor and mower. Drugs and alcohol will effect an operator's ability to operate the equipment safely. Before operating the tractor or mower, an operator on prescription or over-the-counter medication must consult a medical professional regarding any side effects of the medication that would hinder their ability to operate the equipment safely. **NEVER** knowingly allow anyone to operate this equipment when their alertness or coordination is impaired. Serious injury or death to the operator or others could result if the operator is under the influence of drugs or alcohol.

Operation

Pre Start Up Instructions:

1. Make sure tractor motor is shut off and key is removed.
2. Place parking brake on.
3. Read all warning labels & safety decals on mower & tractor.

Mower attachment instructions :

1. Hook up mower to tractor three point hitch.
2. Check PTO drive line make sure it is proper length for tractor.
3. Attach PTO drive line to tractor. Make sure locking collars are securely installed.

Mower start up instructions :

1. Fasten seat belt and start engine.
2. Engage tractor PTO.
3. After blades engage, slowly increase engine speed until desired 540 PTO RPM is achieved.

Mowing instructions :

1. Travel at slower ground speeds until you get used to mowing.
2. Never lift mower head more than 2" off the ground .
3. Never travel faster than you can react to terrain changes.
4. The taller the weeds are, the slower you will have to travel. (Average Speed 0-5 MPH)
5. If foreign object is struck stop mower immediately and check for damages.

Maintenance

General :

1. Always block mower up and remove key from tractor before servicing.

Daily Maintenance :

1. Check spindle drive gear lube level.
2. Thoroughly check mower for loose fasteners & wear or damage before operation.
3. Check all safety devices for damage and wear, make sure they are in good working condition.
4. Make sure all safety decals are undamaged and legible.
5. Check blades and blade bolts for excessive wear or damage.

Periodic Maintenance :

1. Check mower housing for cracks or other damage, fix as needed.
2. Check hydraulic motor for signs of fatigue or excessive wear.
3. Check hydraulic lines and quick disconnects for excessive wear.
4. Check blade carrier for damage or excessive wear.

Blade maintenance :

1. Sharpen blades as required.
2. Never sharpen excessively worn or damaged blades.
3. Always use grinder to sharpen blades.
4. Always follow original sharpening pattern.
5. Never sharpen blade to razor edge always leave 1/16" blunt edge.
6. Do not sharpen back side of blade.
7. Never straighten, weld, or heat mower blade.
8. Never hard surface mower blade, this could cause blade to fail.

Blade Replacement :

1. Use only original equipment blades on this mower.
2. Always replace blades in pairs.
3. Always replace blade bolts when replacing mower blades.

Hydraulic Oil & Filter Maintenance :

1. Change return line filter after first 100 hours of operation. Change filter again at 600 hours of operation.
2. Change oil and filters at 1200 hours of operation. After that continue to change oil filter every 600 hours & oil every 1200 hours of operation.
3. Use Dextron III or equal oil.

Parts

Flail Mower Head Parts Diagram

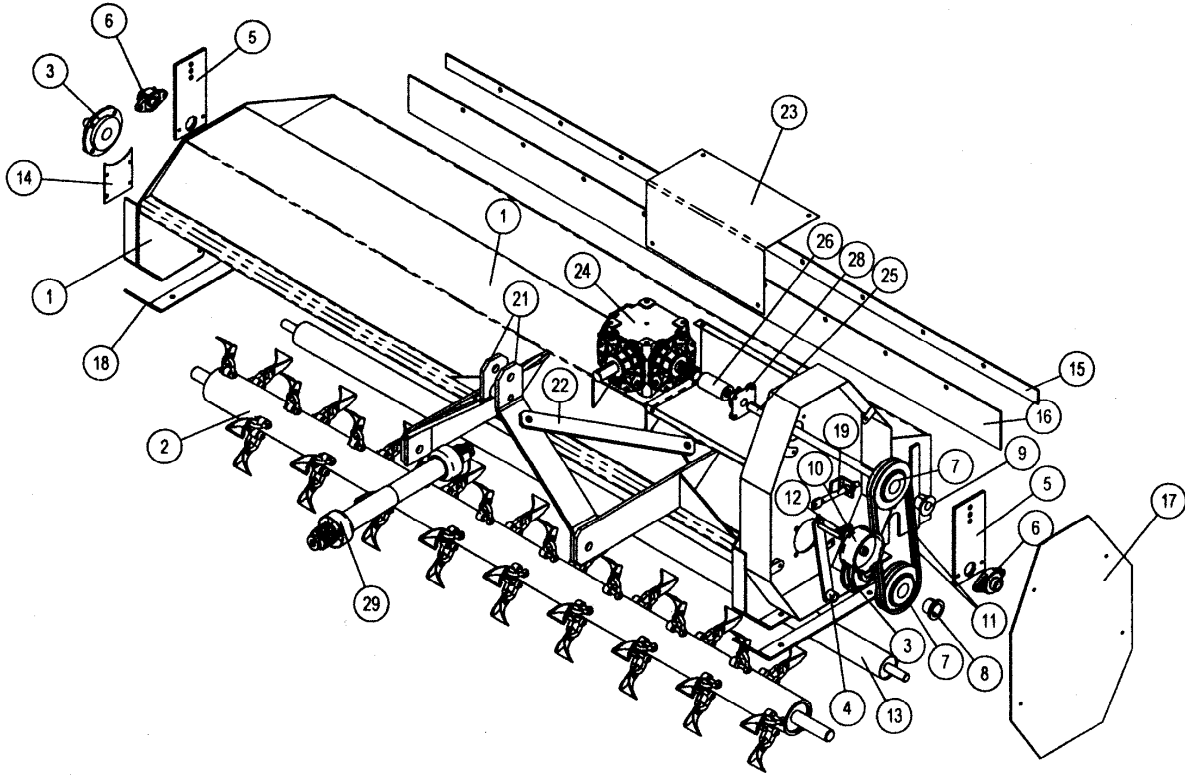

Parts

Flail Mower Head Parts List

| Item Number | Quantity | Part Number | Part Description |
|-------------|----------|-------------|--------------------------------|
| 1 | 1 | 333100 | 60" Housing Weldment |
| 1 | 1 | 333102 | 76" Housing Weldment |
| 1 | 1 | 333104 | 96" Housing Weldment |
| 2 | 1 | 700200 | 60" Cutter Shaft |
| 2 | 1 | 700201 | 76" Cutter Shaft |
| 2 | 1 | 700202 | 96" Cutter Shaft |
| 3 | 2 | 700300 | Cutter Shaft Bearing |
| 4 | 1 | 700310 | 60" Belt Tension Arm |
| 4 | 1 | 700311 | 76" & 96" Belt Tension Arm |
| 5 | 2 | 700319 | Roller Adjustment Plate |
| 6 | 2 | 700340 | Rear Roller Bearing |
| 7 | 2 | 700370 | 60" Drive Pulley |
| 7 | 2 | 700371 | 76" & 96" Drive Pulley |
| 8 | 1 | 700374 | 60" Drive Pulley Bushing |
| 8 | 1 | 700376 | 76" & 96" Drive Pulley Bushing |
| 9 | 1 | 700375 | 60" Drive Pulley Bushing |
| 9 | 1 | 700377 | 76" & 96" Drive Pulley Bushing |
| 10 | 1 | 700372 | 60" Belt Tension Pulley |
| 10 | 1 | 700373 | 76" & 96" Belt Tension Pulley |
| 11 | 1 | 700400 | 60" Drive Belt |
| 11 | 1 | 700401 | 76" & 96" Drive Belt |
| 12 | 1 or 2 | 700380 | Belt Tension Spring |
| 13 | 1 | 700500 | 60" Rear Roller |
| 13 | 1 | 700502 | 76" Rear Roller |
| 13 | 1 | 700504 | 96" Rear Roller |
| 14 | 1 | 700210 | Closure Plate |
| 15 | 1 | 700520 | 60" Rear Flap Retainer Strap |
| 15 | 1 | 700521 | 76" Rear Flap Retainer Strap |
| 15 | 1 | 700522 | 96" Rear Flap Retainer Strap |
| 16 | 1 | 700530 | 60" Rear Flap |
| 16 | 1 | 700531 | 76" Rear Flap |
| 16 | 1 | 700532 | 96" Rear Flap |
| 17 | 1 | 777000 | Drive Cover |
| 18 | 2 | 700215 | Wear Runner |

Parts

Flail Mower Head Parts List

| Item Number | Quantity | Part Number | Part Description |
|-------------|----------|-------------|-------------------------|
| 21 | 2 | 333200 | Three Point Mount |
| 22 | 2 | 333201 | Three Point Mount Brace |
| 23 | 1 | N/A | Drive Shaft Cover |
| 24 | 1 | 333501 | Gear Box |
| 25 | 1 | N/A | Drive Shaft |
| 26 | 1 | 333300 | Drive Shaft Coupler |
| 28 | 1 | 333310 | Drive Bearing |
| 29 | 1 | 333000 | PTO Drive Line |

Parts

Flail Mower Cutter Shaft Parts Diagram

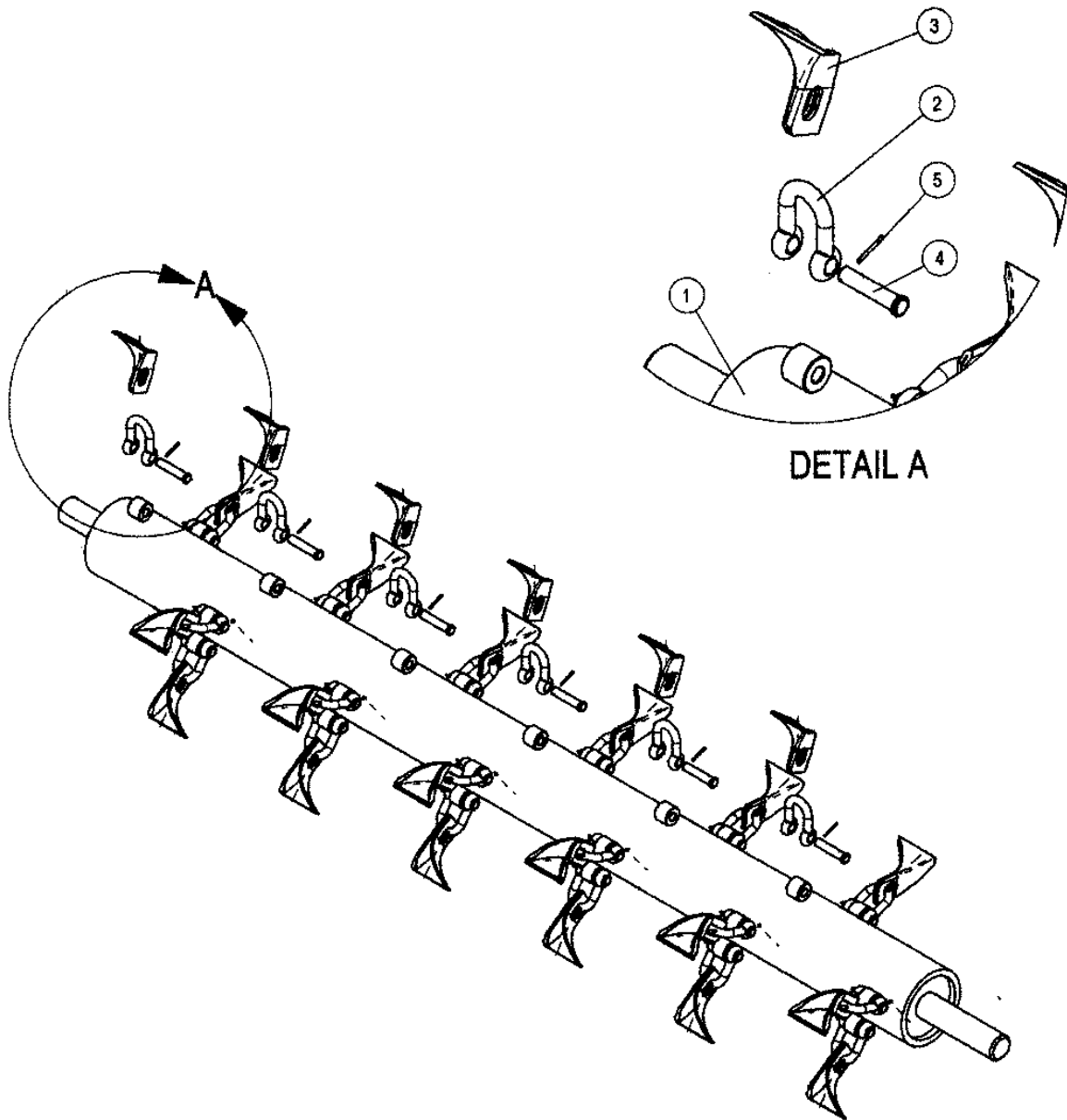

Parts

Flail Cutter Shaft Parts List

| Item Number | Quantity | Part Number | Part Description |
|-------------|----------|-------------|------------------------------------|
| 1 | 1 | 700200 | 60" Cutter Shaft Weldment |
| 1 | 1 | 700201 | 76" Cutter Shaft Weldment |
| 2 | 30 / 35 | 700900 | Blade Clevis |
| 3 | 30 / 35 | 700905 | Flail Blade (Folded Cup Style) |
| 3 | 60 / 70 | 700903 | Flail Blade (Standard L Knife) |
| 3 | 60 / 70 | 700907 | Flail Blade (Heavy Duty L Knife) |
| 4 | 30 / 35 | 700910 | Clevis Pin |
| 5 | 30 / 35 | 900911 | Cotter Pin |