

**McKenzie Mid Mounted Ditch Mower
Operator Manual
With Parts Listing**

**McKenzie Supply & Equipment Ltd.
1660 20-1/2 Street
Rice Lake WI 54868
715-234-6848
Email : mckequip@chibardun.net
Web Site : www.mckenzieltd.com**

Table Of Contents

Safety Introduction	1
Safety Messages	2-4
Operation Section	5
Maintenance Section	6
Parts Section	7-19
Mower Base Frame Parts Diagram	7
Mower Base Frame Parts List	8
Oil Reservoir Parts Diagram & List	9
Mower Housing Parts Diagram	10
Mower Housing Parts List	11
Spindle Drive Parts Diagram	12
Spindle Drive Parts List	13
Flail Mower Head Parts Diagram	14
Flail Mower Head Parts List	15
Flail Cutter Shaft Parts Diagram	16
Flail Cutter Shaft Parts List	17
Mower On / Off Valve Parts Diagram	18
Mower On / Off Valve Parts List	19

Safety Introduction

A safe and careful operator is the best operator. Safety is of primary importance to the manufacturer and should be to the owner operator. Most accidents can be avoided by being aware of your equipment, your surroundings, and observing certain precautions. The safety section of this manual includes a list of safety messages that, if followed, will help protect the operator and bystanders from injury or death. Read and understand these safety messages before assembling, operating or servicing this attachment. This equipment should only be operated by those persons who have read the manual, who are responsible and trained, and who know how to do so safely and responsibly.

The safety alert symbol combined with a signal word, as seen below, is used throughout this manual and on decals which are attached to the equipment. The safety and alert symbol means: “**ATTENTION! BECOME ALERT! YOUR SAFETY IS INVOLVED!**” The symbol and signal word are intended to warn the owner / operator of impending hazards and the degree of possible injury faced when operating this equipment.

Practice all usual and customary safe working precautions and above all remember safety is up to YOU! Only YOU can prevent serious injury or death from unsafe practices.

CAUTION!

This symbol designates the lowest level of safety message; **warns of possible injury**. Decals located on the equipment with this signal word are black and yellow.



WARNING!

This symbol warns of **serious injury or possible death!** Decals located on the equipment with this signal word are black and orange



DANGER!

This symbol warns of **imminent death / critical injury!** Decals located on the equipment with this signal word are red and white.



READ, UNDERSTAND, and FOLLOW the following safety messages. Serious injury or death may occur unless care is taken to follow the warnings and instructions stated in the safety messages. Always use common sense to avoid hazards.

Safety

DANGER!



Never operate the mower or tractor until you have read and completely understand this owner / operator manual, and the tractor operator manual, and each of the safety messages found in this manual and on the tractor and mower. Learn how to stop tractor engine suddenly in an emergency. Never allow inexperienced or untrained personnel to operate the tractor and mower without supervision. Make sure operator has fully read and understood the manuals prior to operation.

WARNING!



Always maintain the safety decals in good readable condition. If the decals are missing, damaged, or unreadable, obtain and install replacement decals immediately.

WARNING!



Operate this mower only on a tractor equipped with an approved roll-over protection system (ROPS). Always wear seat belt. Serious injury or even death could result from falling off tractor, particularly during a roll-over, when operator could be pinned under tractor.

WARNING!



Do not modify or alter mower. Do not permit anyone to modify or alter mower, or any of its components or any mower function.

DANGER!



BEFORE leaving the tractor seat, always engage parking brake and turn off attachment, stop engine, remove key, and wait for all moving mower parts to stop. Never dismount power unit with the engine running. Operate controls from power unit seat only.

WARNING!



Never transport tractor & mower with mower blades engaged. This will cause serious safety concerns.

Safety

DANGER! Never allow children or other persons to ride on tractor or mower. Falling off can result in serious injury or death.



DANGER! Never work under the mower, or any lifted component unless the mower is securely supported or blocked up to prevent sudden or inadvertent falling which could result in serious injury or death.



DANGER! Do not operate the mower with hydraulic oil leaking. Oil is expensive and its presence could present a hazard. Do not check for leaks with your hand! Use a piece of heavy paper or cardboard. High pressure oil streams from breaks in the line could penetrate the skin and cause tissue damage including gangrene. If oil does penetrate skin, have the injury treated immediately by a physician knowledgeable and skilled in this procedure.



WARNING! The operator and all support personnel should wear hard hats, safety shoes, safety glasses, and proper hearing protection at all times for protection from injury including injury from items thrown by the mower.



WARNING! Periodically inspect all moving parts for wear or damage and replace when necessary with authorized service parts. Look for loose fasteners, worn or broken parts, and leaky or loose fittings. Make sure all pins have cotter pins, retaining bolts, and washers if required. Serious injury may occur from not properly maintaining this mower in good working order.



DANGER! Extreme care should be taken when operating near loose objects such as gravel, rock, wire, and other debris. Inspect the area before mowing. Foreign objects should be removed from the site to prevent mower damage and / or bodily injury or even death. Any objects that cannot be removed must be clearly marked and carefully avoided by the operator. Stop mowing immediately if blades strike foreign object. Repair all damage and make certain rotor or blade carrier is balanced before resuming mowing.



Safety

DANGER!



All safety shields, guards and safety devices including but not limited to: Deflectors, chain guards, steel guards, and retractable door shields should be used and maintained in good working condition. All safety devices should be carefully inspected at least daily for missing or broken components. Missing, broken, or worn items must be replaced at once to reduce the possibility of injury or death from thrown objects, entanglement, or blade contact.

DANGER!



Never operate mower in raised position. Raising mower off the ground creates possibility of objects being thrown from mower.

DANGER!



Never service attachment with tractor engine running. Before performing service work shut off engine remove key and make sure attachment is securely blocked.

DANGER!



The rotating parts of this mower have been designed and tested for rugged use. However, the blades could flail upon impact with heavy, solid objects such as metal guards rails and concrete structures. Such impact could cause the broken object to be thrown outward at very high velocities. To reduce the possibility of property damage serious injury, or even death, never allow the cutting blades to contact such obstacles.

DANGER!



NEVER use drugs or alcohol immediately before or while operating the power unit and attachment. Drugs and alcohol will effect an operator's ability to operate the equipment safely. Before operating the power or attachment, an operator on prescription or over-the-counter medication must consult a medical professional regarding any side effects of the medication that would hinder their ability to operate the equipment safely. **NEVER** knowingly allow anyone to operate this equipment when their alertness or coordination is impaired. Serious injury or death to the operator or others could result if the operator is under the influence of drugs or alcohol.

Operation

PRE START UP INSTRUCTIONS:

1. Make sure tractor motor is shut off and key is removed.
2. Read all warning decals and labels.
3. Ensure mower is in good operating condition, ensure that all bolts are tight.
4. Make sure blades swing freely, always check blades for cracks or damage, make sure blade bolts are tight.
5. Make sure blade carrier bolts are tight and undamaged.
6. Make sure that all guards are installed properly and undamaged.
7. Lubricate all lubrication points.
8. Make sure that you know how to stop tractor engine in case of emergency.

MOWER START UP INSTRUCTIONS:

1. Fasten seat belt and start tractor engine.
2. With mower in safe mowing position, tractor engine at an idle engage mower blades, make sure that blades start to turn, if blades do not shut off tractor and repair problem.
3. If mower checks out disengage mower blades put mower into transport position, install transport safety stops, and proceed to mowing area.

MOWING INSTRUCTIONS:

1. Make sure to follow all the safety messages in this manual and all safety labels, and decals on mower, and tractor.
2. Check area to be mowed to make sure there is no foreign objects, if there are any foreign objects, remove them before mowing, if unable to remove object make sure that it is properly marked, so operator can avoid while mowing.
3. Give complete and undivided attention to the job at hand.
4. Proper ground speed for cutting will depend upon the height, type, and density of material to be cut. Normally, ground speed will be range from 2 to 5 mph. tall dense material should be cut at low speed while thin medium, height material can be cut faster ground speed.
5. Stand clear of mower while in operation.
6. Never operator mower in the vicinity of other persons.
7. If foreign object is struck, stop mowing, shut off mower and tractor engine, remove key, and check for damages before you resume mowing.

Maintenance

DAILY MAINTENANCE:

1. Make sure all warning labels are in legible condition.
2. **LUBRICATE ALL LUBRICATION POINTS.**
3. Inspect mower for damage or excessive wear, replace any damaged or worn parts.
4. Inspect mower for loose or broken bolts, if loose tighten, if broke replace.
5. Inspect mower blades and blade carrier for excessive wear or damage, replace as required.
6. Inspect mower for cracks or signs of stress marks, repair as required.
7. Inspect all hydraulic lines for excessive wear or damage, replace as required.
8. Inspect all hydraulic line fasteners make sure hydraulic lines are not moving to a point that they can be damaged.

HYDRAULIC OIL MAINTENANCE:

1. Change return line filter after first 100 hours of operation. Change filter again at 600 hours of operation.
2. Change oil and filters at 1200 hours. After that continue to change filters every 600 hours and oil every 1200 hours of operation.
3. Use dextrin III automatic trans mission fluid.

MOWER BLADE MAINTENANCE:

1. Inspect mower blades before each use to determine that they are properly installed, and in good working condition.
2. Blades should be replaced when they are excessively nicked or worn, bent or if any other damage exists.
3. Blades should always be replaced in pairs to maintain balance. If one blade is bad, they are both bad.
4. Always replace blade bolts and nuts when replacing blades.
5. When sharpening blades, it is important to sharpen both blades the same, to maintain balance. NEVER sharpen blades razor sharp, always leave 1-/16" blunt edge.
6. Always use hand grinder to sharpen blades. NEVER heat or pound blade edge. NEVER sharpen back sides of blade, follow original sharpening pattern.

BOLT TORQUE SPECIFICATIONS:

1. 5- 3/4" Deck to trunion bolts 250 FT. LBS (USE RED LOCKTITE)
2. 6- 5/8" Socket head blade carrier bolts 200 FT. LBS. (USE RED LOCKTITE)
3. 2 or 4 1-1/8" blade shoulder bolts 450 FT. LBS. (USE RED LOCKTITE)

Parts

Mower Base Frame Parts Diagram

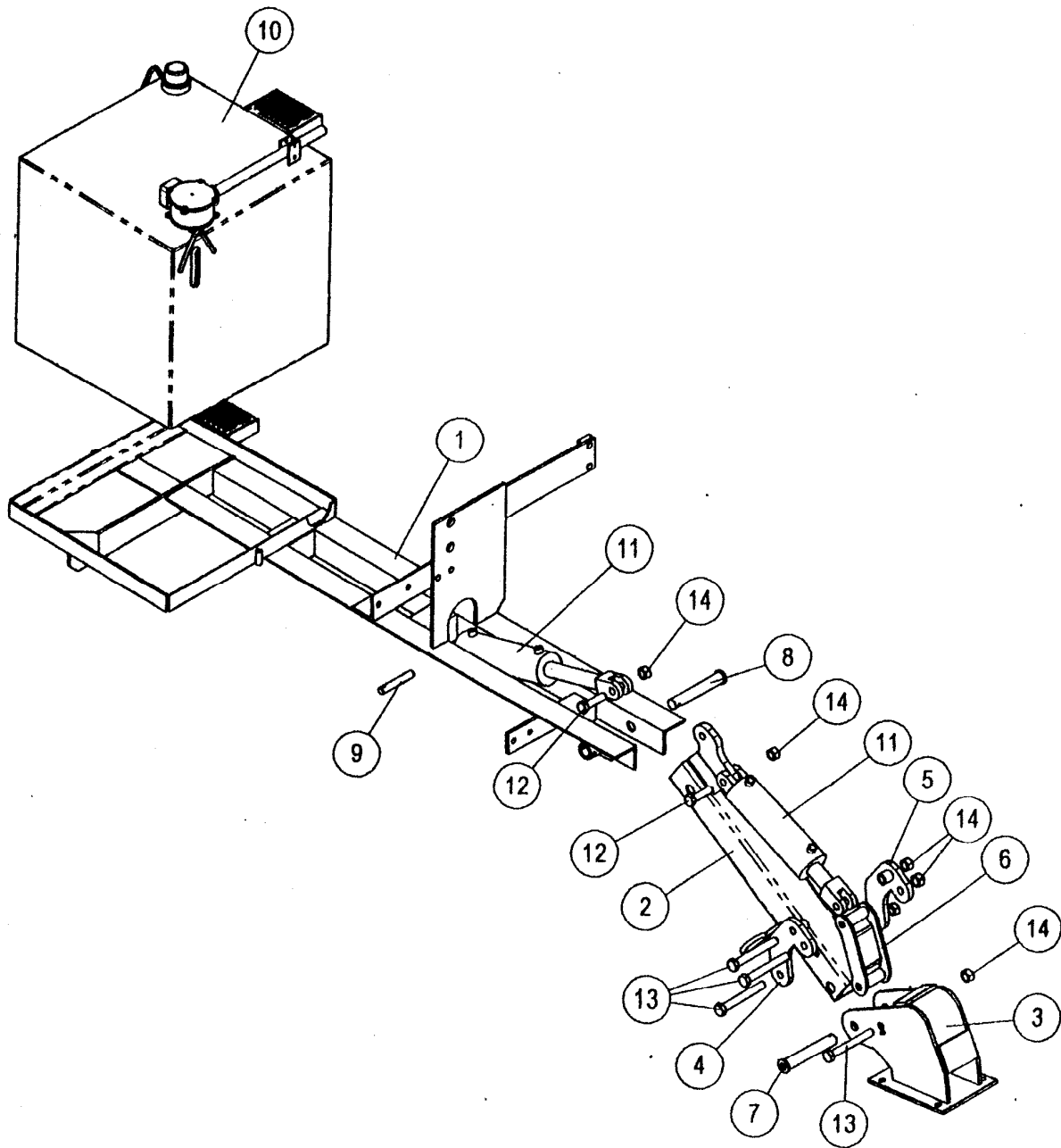

Parts

Mower Base Frame Parts List

Item Number	Quantity	Part Number	Part Description
1	1	200100	Main Frame Weldment
2	1	200110	Linkage Arm Weldment
3	1	200120	Trunion Weldment
4	1	500131	Deck Roll Linkage (Outer Rear)
5	1	500132	Deck Roll Linkage (Outer Front)
6	1	500130	Deck Roll Linkage (Inner)
7	1	200123	Trunion Linkage Arm Pin
8	1	200124	Main Frame Linkage Arm Pin
9	1	200300	Main Frame Hydraulic Cylinder Pin
10	1	N/A	Hydraulic Oil Tank
11	2	200600	Hydraulic Cylinder
12	2	200700	Bolt
13	4	500015	Deck Roll Linkage Bolt
14	6	500016	Lock Nut
N/A	4	502011	1-1/2" ID x 2-1/8" L Hardened Bushing
N/A	2	502015	1" ID x 2-1/8" L Hardened Bushing

Parts

Oil Reservoir Parts Diagram

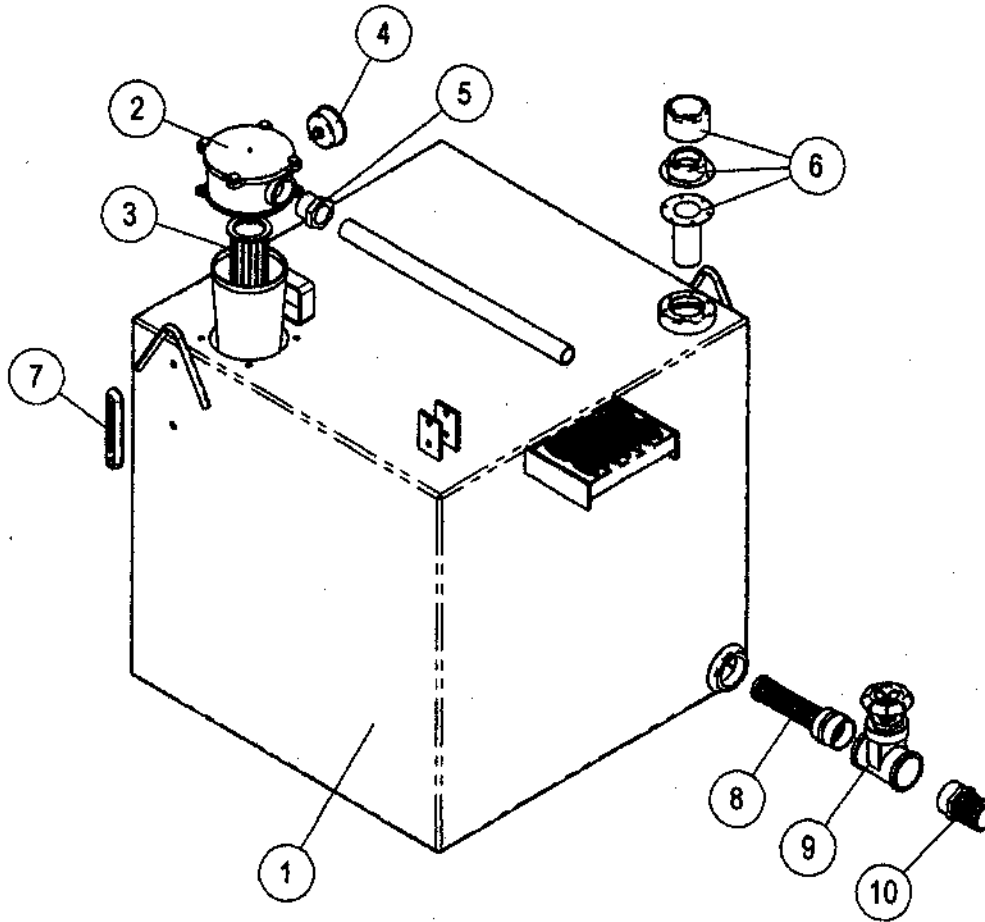

Oil Tank Assembly Parts List

Item Number	Quantity	Part Number	Part Description
1	1	N/A	Custom Walk Over Oil Reservoir
2	1	004110	Oil Filter Assy.
3	1	004115	Replacement Oil Filter Element
4	1	004300	Oil Filter Gauge
5	1	N/A	Pipe Reducer Bushing
6	1	004000	Filler Cap Assembly
7	1	004050	Oil Level Sight Gauge
8	1	004200	Suction Screen (Older Models Only)
9	1	004210	Gate Valve
10	1	004212	King Nipple

Parts

Mower Housing Parts Diagram

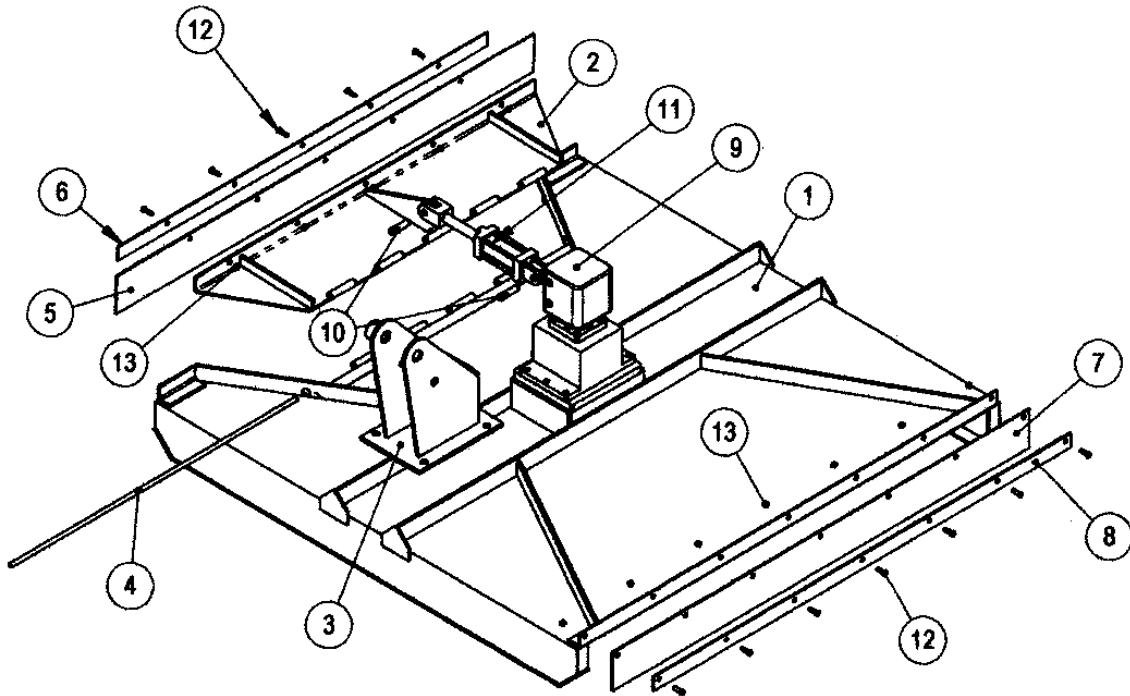

Parts

Mower Housing Parts List

Item Number	Quantity	Part Number	Part Description
1	1	500145	60" Housing Weldment
2	1	500149	Blade Guard Weldment
3	1	500140	Trunion Weldment
4	1	500012	Blade Guard Pin
5	1	500013	Blade Guard Debris Flap
6	1	500014	Blade Guard Debris Flap Retaining Strap
7	1	000116	Rear Debris Flap
8	1	000131	Rear Debris Flap Retaining Strap
9	1	081273	Hydraulic Drive Motor
10	2	500150	Blade Guard Linkage Bar Pin
11	1	500151	Blade Guard Hydraulic Cylinder
11	1	500155	Blade Guard Linkage Bar
12	12	000141	Retainer Strap Bolt
13	12	000142	Retainer Strap Nut

Parts

Spindle Drive Parts Diagram

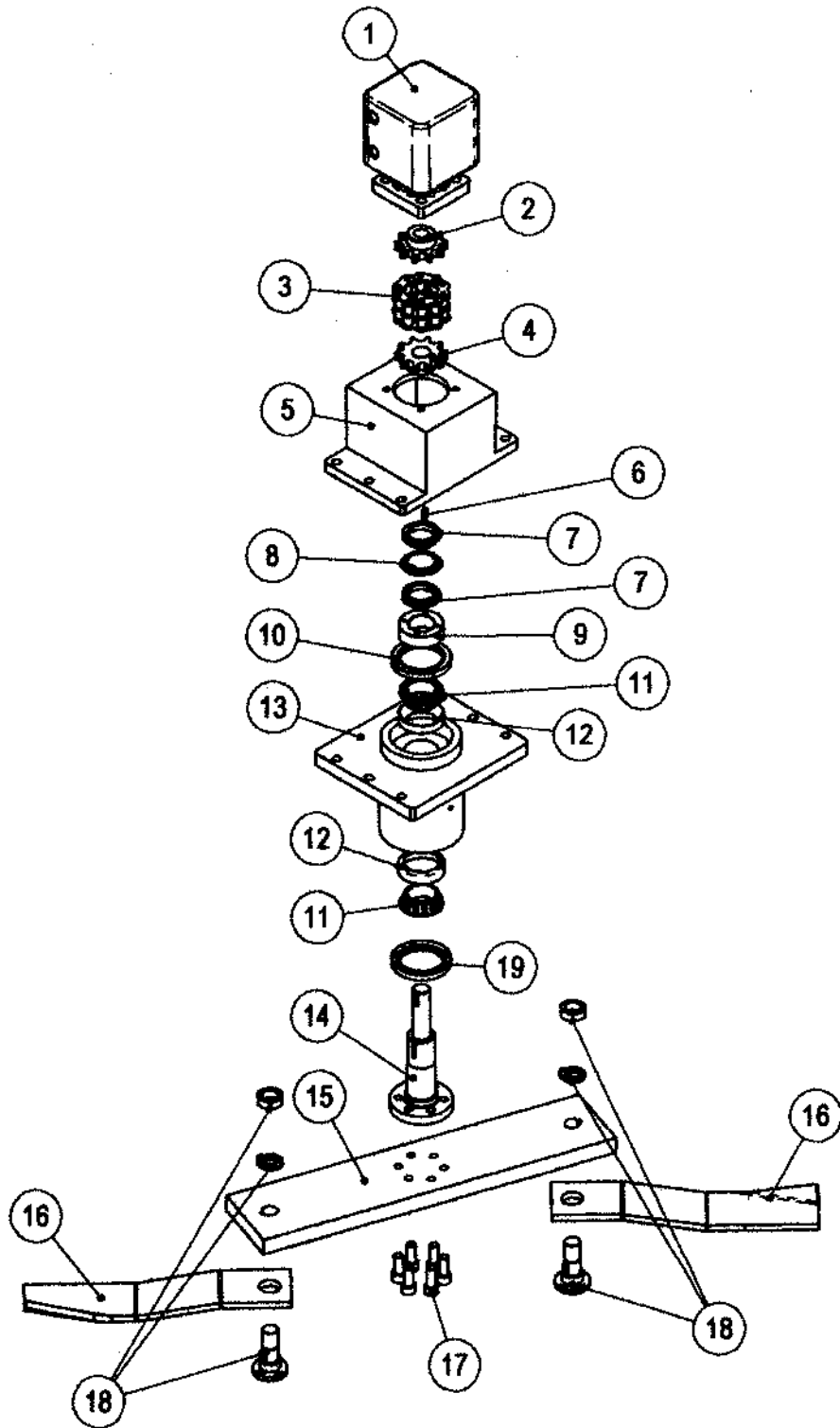

Parts

Spindle Drive Parts List

Item Number	Quantity	Part Number	Part Description
1	1	081273	Hydraulic Drive Motor
2	1	500601	Motor Chain Coupler Half
3	1	500603	Chain Coupler
4	1	500605	Spindle Chain Coupler Half
5	1	500160	Drive Motor Mount
6	1	500608	Spindle Key
7	2	500609	Spindle Bearing Nut
8	1	500611	Spindle Bearing Nut Lock Washer
9	1	500710	Seal Spacer Nut
10	1	500613	Top Oil Seal
11	2	500620	Tapered Bearing Cone
12	2	500621	Tapered Bearing Cup
13	1	500162	Spindle Housing Weldment
14	1	500712	Spindle
15	1	500714	Bar Blade Carrier
15	1	500715	Circle Blade Carrier
16	2	000196	Grass Blade
16	2	000197	Brush Blade
17	6	500622	Blade Carrier Bolt & Washer
18	2	000227	Grass Blade Bolt & Lock Nut
18	2	000228	Brush Blade Bolt & Lock Nut
19	1	500614	Bottom Oil Seal

NOTE:

Item #17 Should Be Torqued To 200 Ft Lbs & Red Lock Tight Used On Threads.
Item #18 Should Be Torqued To 450 Ft Lbs & Red Lock Tight Used On Threads.

Parts

Flail Mower Head Parts Diagram

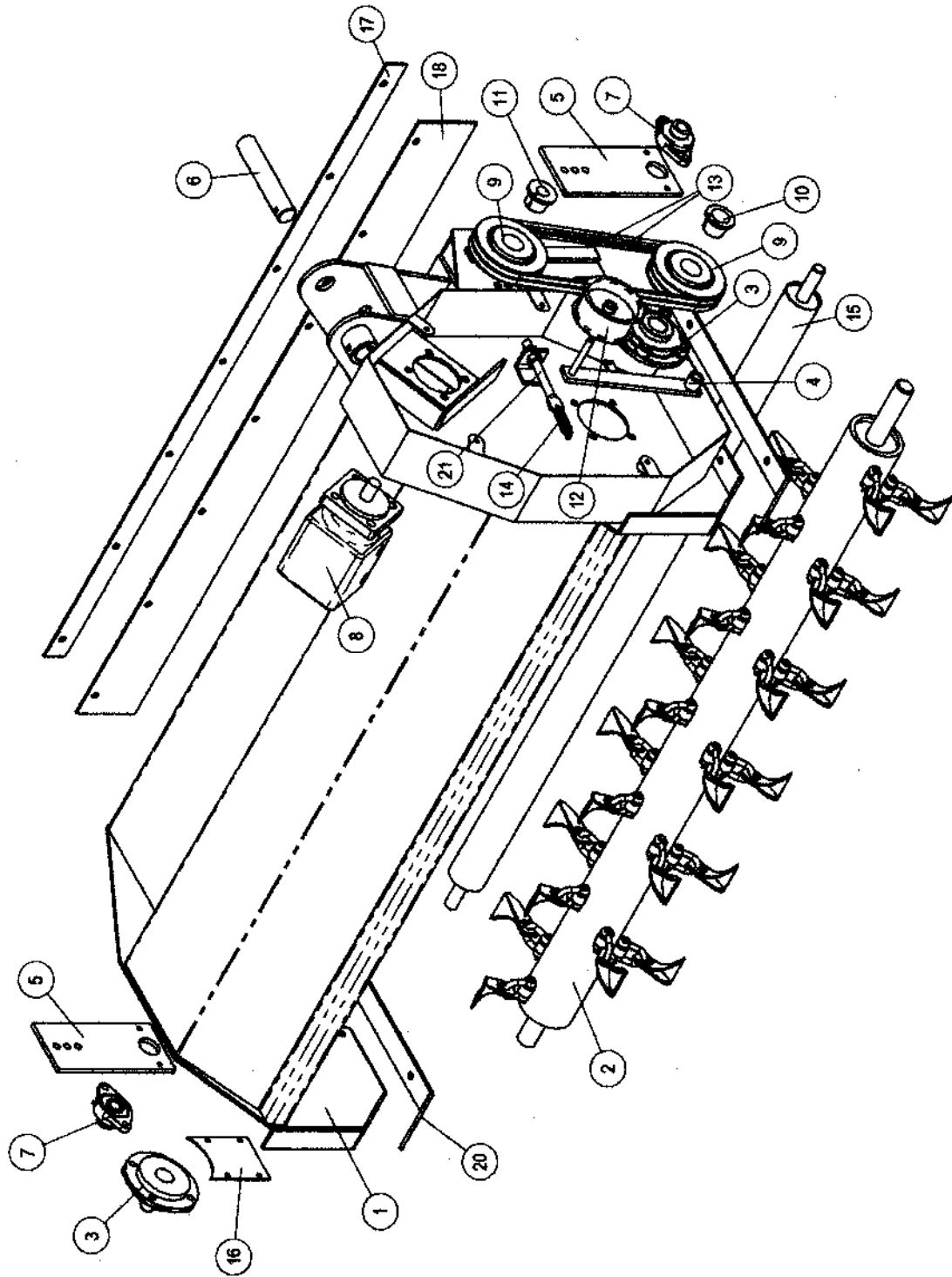

Parts

Flail Mower Head Parts List

Item Number	Quantity	Part Number	Part Description
1	1	700100	60" Mower Housing Weldment
1	1	700101	76" Mower Housing Weldment
2	1	700200	60" Cutter Shaft Weldment
2	1	700201	76" Cutter Shaft Weldment
3	2	700300	Cutter Shaft Bearing
4	1	700310	Belt Tensioner Arm Weldment
5	2	700319	Rear Roller Adjustment Plate
6	1	700325	Trunion Pin
7	2	700340	Rear Roller Bearing
8	1	081234	Hydraulic Drive Motor
9	2	700370	60" Drive Pulley
9	2	700371	76" Drive Pulley
10	1	700374	60" Lower Drive Pulley Bushing
10	1	700376	76" Lower Drive Pulley Bushing
11	1	708375	60" Upper Drive Pulley Bushing
11	1	708377	76" Upper Drive Pulley Bushing
12	1	700372	Belt Tensioner Pulley
13	2	700400	60" Drive Belt
13	2	700401	76" Drive Belt
14	1 Or 2	700380	Belt Tensioner Spring
15	1	700500	60" Rear Roller Weldment
15	1	700501	76" Rear Roller Weldment
16	1	700210	Closure Plate
17	1	700520	60" Rear Flap Retainer Strap
17	1	700521	76" Rear Flap Retainer Strap
18	1	700530	60" Rear Flap
18	1	700531	76" Rear Flap
20	2	700215	Wear Runner
21	1	700381	60" Belt Tensioner Eye Bolt
21	1	700382	76" Belt Tensioner Eye Bolt

Parts

Flail Mower Cutter Shaft Parts Diagram

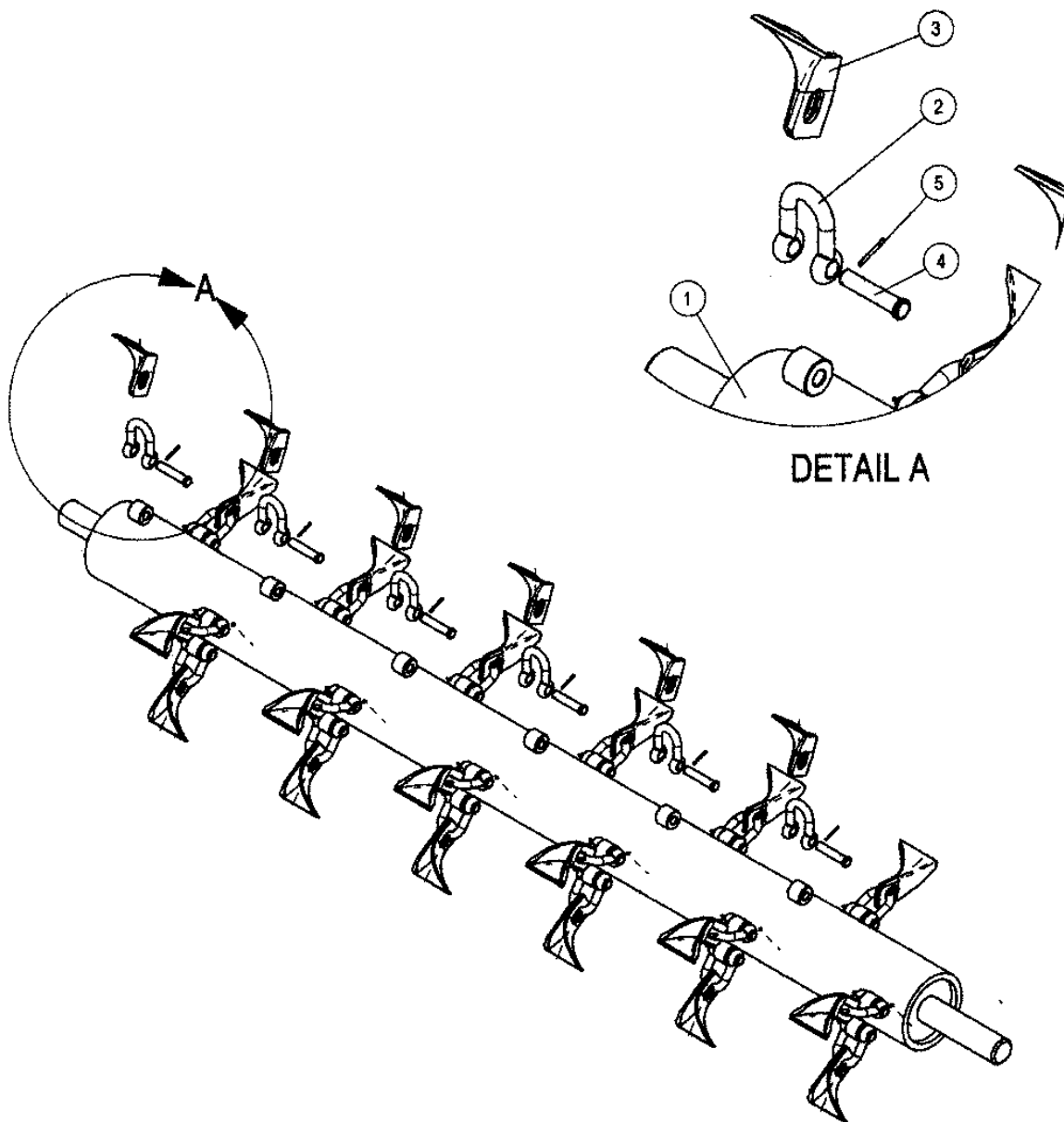

Parts

Flail Cutter Shaft Parts List

Item Number	Quantity	Part Number	Part Description
1	1	700200	60" Cutter Shaft Weldment
1	1	700201	76" Cutter Shaft Weldment
2	30 / 35	700900	Blade Clevis
3	30 / 35	700905	Flail Blade (Folded Cup Style)
3	60 / 70	700903	Flail Blade (Standard L Knife)
3	60 / 70	700907	Flail Blade (Heavy Duty L Knife)
4	30 / 35	700910	Clevis Pin
5	30 / 35	900911	Cotter Pin

Parts

Mower On / Off Valve Parts Diagram

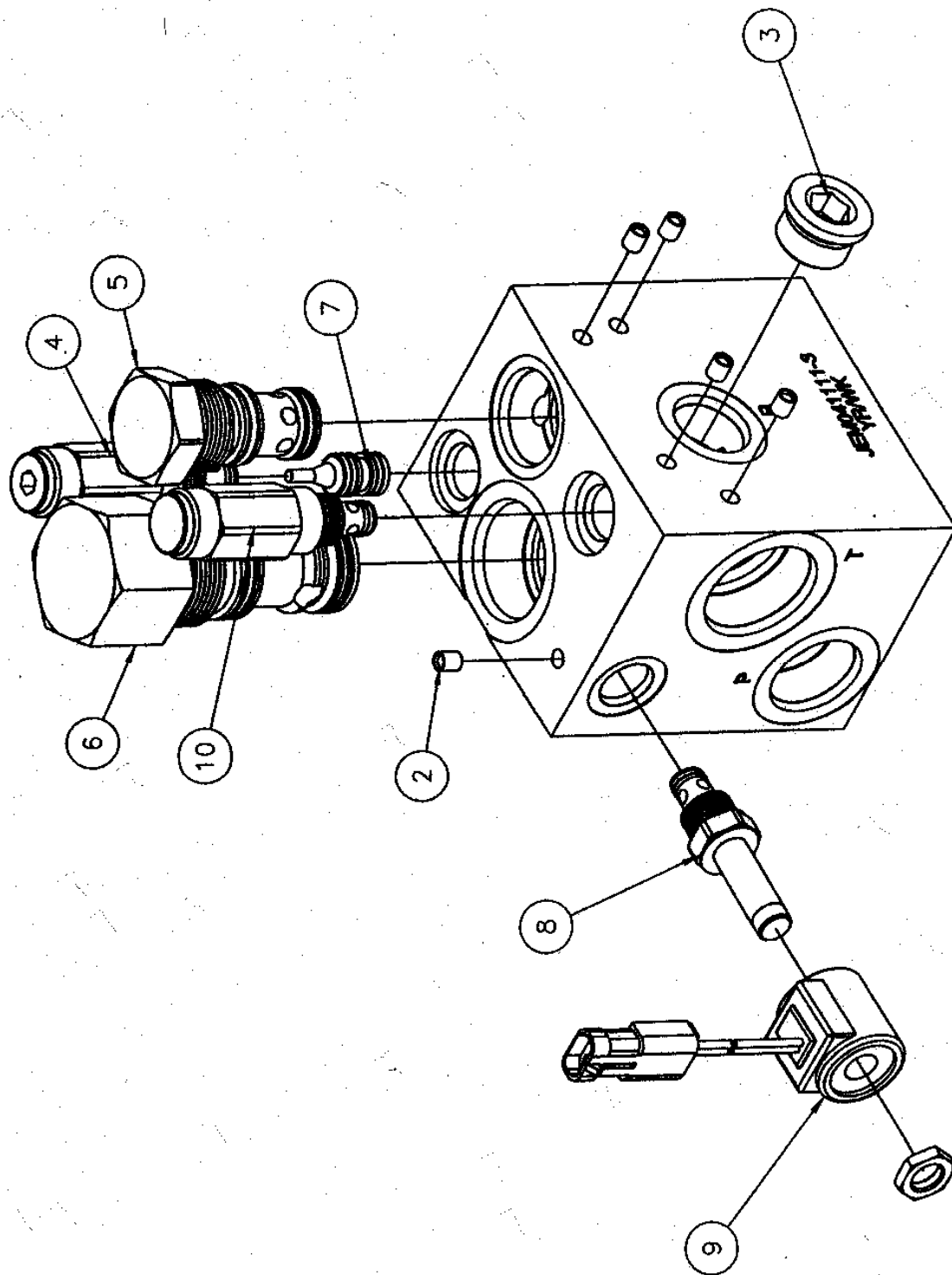

Parts

Mower On / Off Valve Parts List

Item Number	Quantity	Part Number	Part Description
1	1	600205	Manifold Block
2	5	600360	Expander Plug
3	1	600220	Plug
4	1	600818	Relief Valve
5	1	600375	Vented Spool Logic Element
6	1	600816	Vented Spool Logic Element
7	1	600500	Pilot Piston
8	1	600230	Cartridge Valve
9	1	600423	12 VDC Coil
10	1	600834	Relief Valve