

**Billy Goat Mower
Operator Manual
With Parts Listing**

**McKenzie Supply & Equipment Ltd.
1660 20-1/2 Street
Rice Lake WI 54868
715-234-6848
Email : mckequip@chibardun.net
Web Site : www.mckenzieltd.com**

Table Of Contents

Safety Introduction	1
Safety Messages	2-4
Operation Section	5
Maintenance Section	6
Parts Section	7-14
Billy Goat Mower Housing Parts Diagram	7
Billy Goat Mower Housing Parts List	8
Billy Goat Spindle Parts Diagram	9
Billy Goat Spindle Parts List	10
Billy Goat Hydraulic Relief Valve Parts List	11
Safety Decal Parts Diagram	12
Safety Decal Parts List	12
Safety Decal Picture Identification Page	13

Safety Introduction

A safe and careful operator is the best operator. Safety is of primary importance to the manufacturer and should be to the owner operator. Most accidents can be avoided by being aware of your equipment, your surroundings, and observing certain precautions. The safety section of this manual includes a list of safety messages that, if followed, will help protect the operator and bystanders from injury or death. Read and understand these safety messages before assembling, operating or servicing this attachment. This equipment should only be operated by those persons who have read the manual, who are responsible and trained, and who know how to do so safely and responsibly.

The safety alert symbol combined with a signal word, as seen below, is used throughout this manual and on decals which are attached to the equipment. The safety and alert symbol means: “**ATTENTION! BECOME ALERT! YOUR SAFETY IS INVOLVED!**” The symbol and signal word are intended to warn the owner / operator of impending hazards and the degree of possible injury faced when operating this equipment.

Practice all usual and customary safe working precautions and above all remember safety is up to YOU! Only YOU can prevent serious injury or death from unsafe practices.

CAUTION!

This symbol designates the lowest level of safety message; **warns of possible injury**. Decals located on the equipment with this signal word are black and yellow.



WARNING!

This symbol warns of **serious injury or possible death!** Decals located on the equipment with this signal word are black and orange



DANGER!

This symbol warns of **imminent death / critical injury!** Decals located on the equipment with this signal word are red and white.



READ, UNDERSTAND, and FOLLOW the following safety messages. Serious injury or death may occur unless care is taken to follow the warnings and instructions stated in the safety messages. Always use common sense to avoid hazards.

Safety

DANGER!



Never operate the attachment or power unit until you have read and completely understand this operator manual, and the power unit operator manual, and each of the safety messages found in this manual and on the power unit and attachment. Learn how to stop power unit engine suddenly in an emergency. Never allow inexperienced or untrained personnel to operate the power unit and attachment without supervision. Make sure operator has fully read and understood the manuals prior to operation.

WARNING!



Always maintain the safety decals in good readable condition. If the decals are missing, damaged, or unreadable, obtain and install replacement decals immediately.

WARNING!



Operate this attachment only on a power unit equipped with an approved roll-over protection system (ROPS). Always wear seat belt. Serious injury or even death could result from falling off power unit, particularly during a roll-over, when operator could be pinned under power unit.

WARNING!



Do not modify or alter this attachment. Do not permit anyone to modify or alter this attachment, or any of its components or any attachment function.

WARNING!



Always make sure hydraulic motor on attachment is rated for the flow of power unit. Serious injury or even death could result from attachment with improper hydraulic flow.

DANGER!



BEFORE leaving the power unit seat, always engage parking brake and turn off attachment, stop engine, remove key, and wait for all moving parts to stop. Never dismount power unit with the engine running. Operate controls from power unit seat only.

Safety

DANGER!



Never allow children or other persons to ride on power unit or attachment. Falling off can result in serious injury or death.

DANGER!



Never work under the attachment, or any lifted component unless the attachment is securely supported or blocked up to prevent sudden or inadvertent falling which could result in serious injury or death.

DANGER!



Do not operate attachment with hydraulic oil leaking. Oil is expensive and its presence could present a hazard. Do not check for leaks with your hand! Use a piece of heavy paper or cardboard. High pressure oil streams from breaks in the line could penetrate the skin and cause tissue damage including gangrene. If oil does penetrate skin, have the injury treated immediately by a physician knowledgeable and skilled in this procedure.

WARNING!



The operator and all support personnel should wear hard hats, safety shoes, safety glasses, and proper hearing protection at all times for protection from injury including injury from items thrown by the attachment.

WARNING!



Periodically inspect all moving parts for wear or damage and replace when necessary with authorized service parts. Look for loose fasteners, worn or broken parts, and leaky or loose fittings. Make sure all pins have cotter pins and washers if required. Serious injury may occur from not properly maintaining this attachment in good working order.

DANGER!



Extreme care should be taken when operating near loose objects such as gravel, rock, wire, and other debris. Inspect the area before mowing. Foreign objects should be removed from the site to prevent machine damage and / or bodily injury or even death. Any objects that cannot be removed must be clearly marked and carefully avoided by the operator. Stop mowing immediately if blades strike foreign object. Repair all damage and make certain rotor or blade carrier is balanced before resuming mowing.

Safety

DANGER!



All safety shields, guards and safety devices including but not limited to: Deflectors, chain guards, steel guards, and retractable door shields should be used and maintained in good working condition. All safety devices should be carefully inspected at least daily for missing or broken components. Missing, broken, or worn items must be replaced at once to reduce the possibility of injury or death from thrown objects, entanglement, or blade contact.

DANGER!



Never operate mower attachment in raised position. Raising mower off the ground creates possibility of objects being thrown from mower.

DANGER!



Never service attachment with power unit engine running. Before performing service work shut off engine remove key and make sure attachment is securely blocked.

DANGER!



The rotating parts of this attachment have been designed and tested for rugged use. However, the blades could flail upon impact with heavy, solid objects such as metal guards rails and concrete structures. Such impact could cause the broken object to be thrown outward at very high velocities. To reduce the possibility of property damage serious injury, or even death, never allow the cutting blades to contact such obstacles.

DANGER!



NEVER use drugs or alcohol immediately before or while operating the power unit and attachment. Drugs and alcohol will effect an operator's ability to operate the equipment safely. Before operating the power or attachment, an operator on prescription or over-the-counter medication must consult a medical professional regarding any side effects of the medication that would hinder their ability to operate the equipment safely. **NEVER** knowingly allow anyone to operate this equipment when their alertness or coordination is impaired. Serious injury or death to the operator or others could result if the operator is under the influence of drugs or alcohol.

Operation

Pre Start Up Instructions:

1. Make sure skid loader motor is shut off and key is removed.
2. Read all warning decals and labels.
3. Make sure hydraulic drive motor is properly sized for skid loader auxiliary hydraulic flow.

Mower attachment instructions :

1. Attach mower to skid loader. Make sure quick attach lock is secured properly.
2. Attach hydraulic lines to skid loader. Make sure hydraulic quick disconnects are secured properly, disconnection will cause motor damage.

Mower start up instructions :

1. Fasten seat belt and start engine.
2. Engage auxiliary hydraulics. Make sure mower blades engage. (If they do not, Shut off engine immediately).
3. After blades engage, slowly increase engine speed until desired RPM is achieved.

Mowing instructions :

1. Travel at slower ground speeds until you get used to mowing.
2. Never lift mower head more than 2" off the ground .
3. Never travel faster than you can react to terrain changes.
4. The taller the weeds are the slower you will have to travel. (Average Speed 0-5 MPH)
5. If foreign object is struck stop mower immediately and check for damages.

Maintenance

General :

1. Always block mower up and remove key from skid loader before servicing.

Daily Maintenance :

1. Check spindle drive gear lube level.
2. Thoroughly check mower for loose fasteners & wear or damage before operation.
3. Check all safety devices for damage and wear, make sure they are in good working condition.
4. Make sure all safety decals are undamaged and legible.
5. Check blades and blade bolts for excessive wear or damage.

Periodic Maintenance :

1. Check mower housing for cracks or other damage, fix as needed.
2. Check hydraulic motor for signs of fatigue or excessive wear.
3. Check hydraulic lines and quick disconnects for excessive wear.
4. Check blade carrier for damage or excessive wear.

Blade maintenance :

1. Sharpen blades as required.
2. Never sharpen excessively worn or damaged blades.
3. Always use grinder to sharpen blades.
4. Always follow original sharpening pattern.
5. Never sharpen blade to razor edge always leave 1/16" blunt edge.
6. Do not sharpen back side of blade.
7. Never straighten, weld, or heat mower blade.
8. Never hard surface mower blade, this could cause blade to fail.

Blade Replacement :

1. Use only original equipment blades on this mower.
2. Always replace blades in pairs.
3. Always replace blade bolts when replacing mower blades.

Parts

Billy Goat Mower Housing Parts Diagram

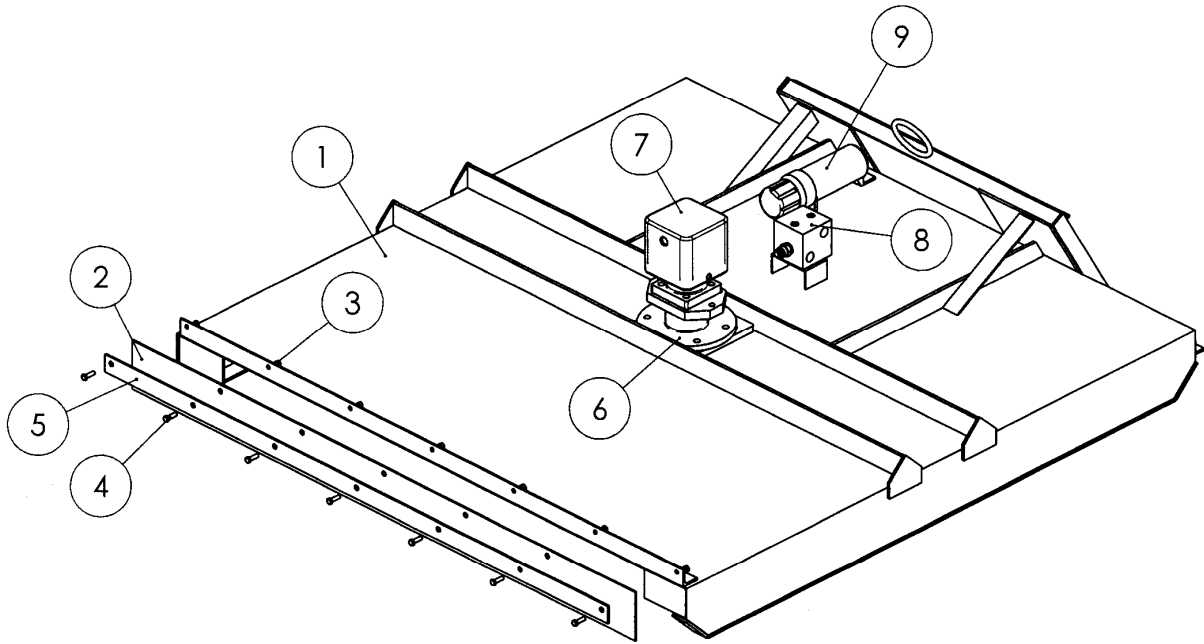

Parts

Billy Goat Mower Housing Parts List

Item #	Part #	Description
1	060010	48" Mower Housing
1	060015	60" Mower Housing
1	060020	72" Mower Housing
2	060060	48" Debris Deflector
2	060061	60" Debris Deflector
2	060062	66" Debris Deflector
3	080001	Lock Nut
4	080002	Bolt
5	060065	48" Debris Deflector Retaining Strap
5	060066	60" Debris Deflector Retaining Strap
5	060067	72" Debris Deflector Retaining Strap
6	080200	Spindle Assy.
7	081203	Code # 03 Hydraulic Drive Motor
7	081205	Code # 05 Hydraulic Drive Motor
7	081207	Code # 07 Hydraulic Drive Motor
7	081210	Code # 10 Hydraulic Drive Motor
7	081211	Code # 11 Hydraulic Drive Motor
7	081212	Code # 12 Hydraulic Drive Motor
7	081213	Code # 13 Hydraulic Drive Motor
7	081214	Code # 14 Hydraulic Drive Motor
8	060160	Hydraulic Relief Valve
9	000006	Operator Manual Storage Canister

Parts

Billy Goat Spindle Parts Diagram

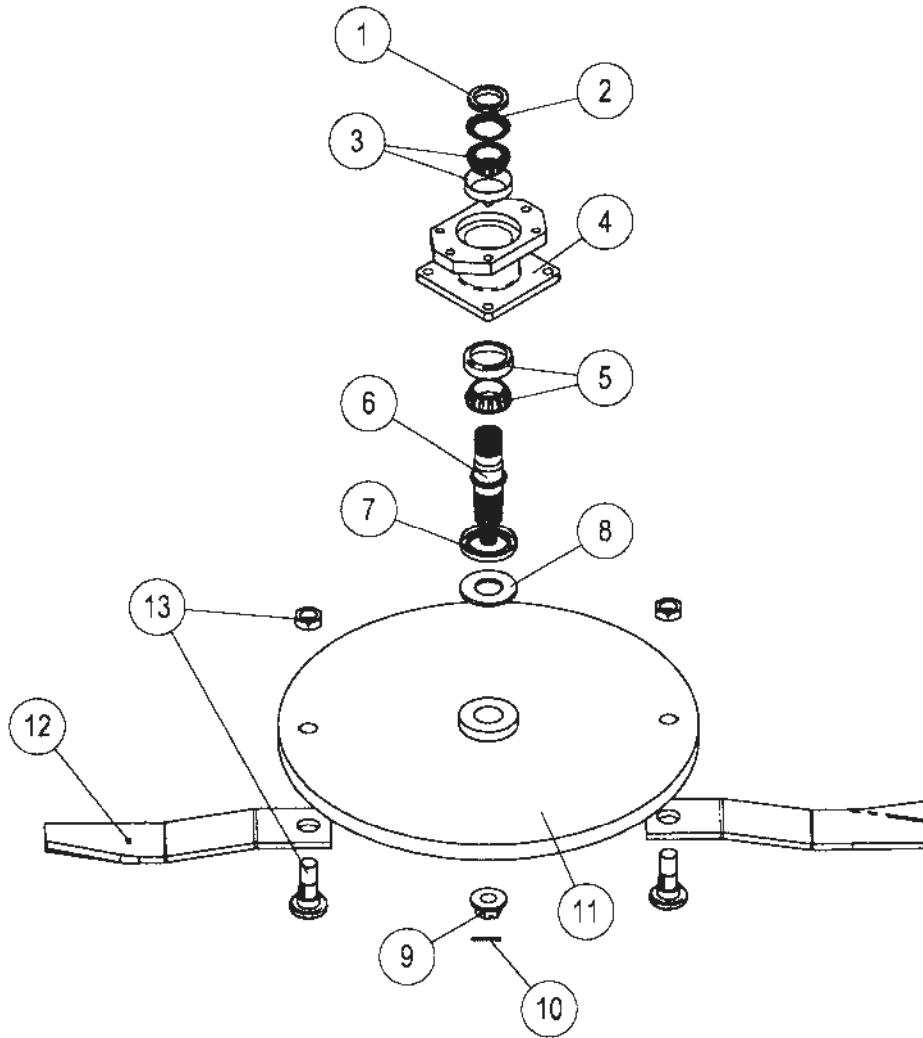

Parts

Billy Goat Spindle Parts List

Item #	Part #	Description
1-10	080200	Spindle Assy.
1	080203	Bearing Nut
2	080204	Bearing Nut Lock Washer
3	080205	Tapered Bearing Assy.
4	N/A	Spindle Housing
5	080206	Tapered Bearing Assy.
6	N/A	Spindle Shaft
7	080202	Oil Seal
8	080201	Oil Seal Guard
9	080207	Blade Hub Retaining Nut
10	080208	Cotter Pin
11	060150	Blade Carrier
12	060100	48" Mower Blade
12	060105	60" Mower Blade
12	060110	72" Mower Blade
13	060130	Blade Bolt Assy.

Parts

Hydraulic Relief Valve Parts List

Part #	Description
060160	Relief Valve Assy.
060165	Valve Body
060170	Relief Cartridge
060175	Check Valve

Parts

Safety Decal Parts Diagram

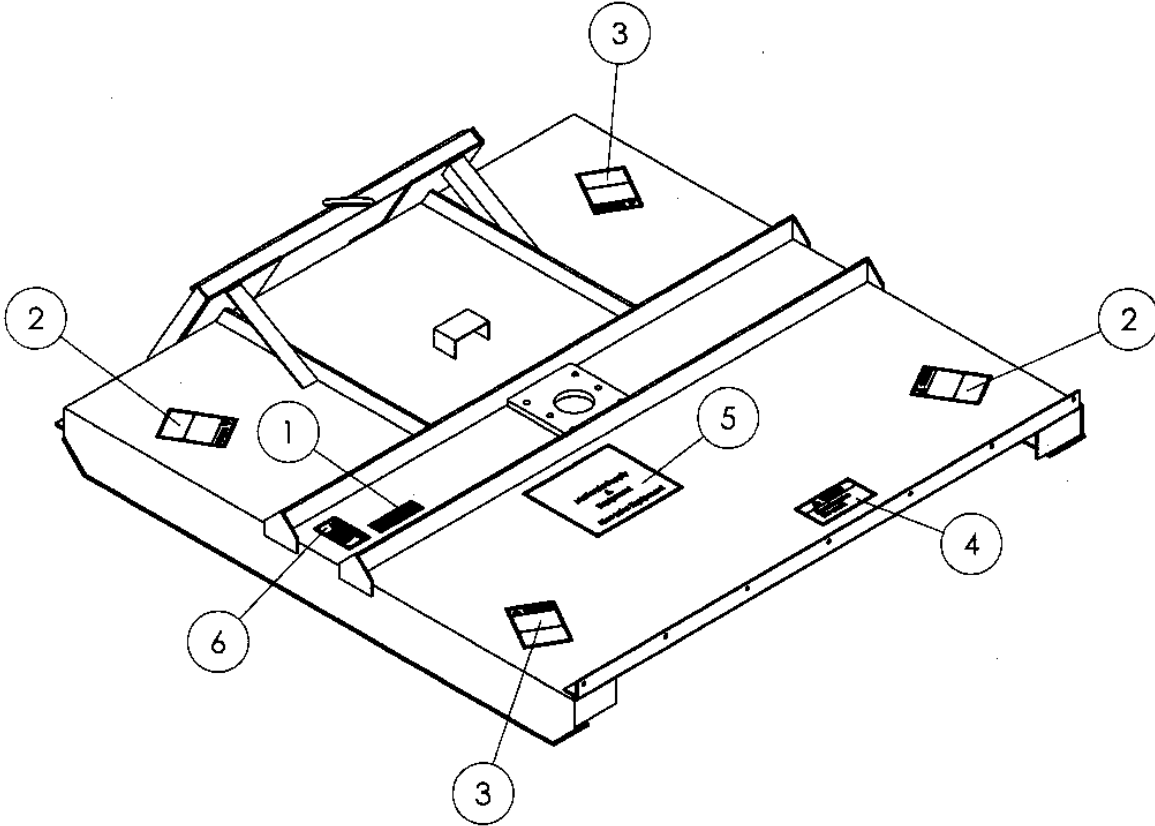

Safety Decal Parts List

Item #	Part #	Description
1	SW-1	Warning (Instruction Decal)
2	SD-2	Danger (Flying Debris)
3	SW-3	Warning (Keep Hands & Feet Clear)
4	SW-4	Warning (Do Not Remove This Guard)
5	PD-10	Billy Goat Decal
6	NP-6	Name Plate

Parts

Safety Decal Picture Identification Page



Part # - SW-3

Part # - SW-1

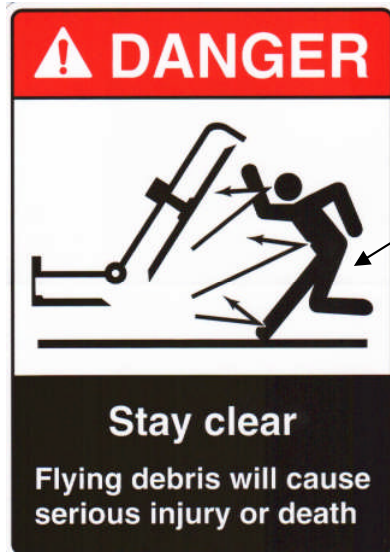

Part # - SD-2

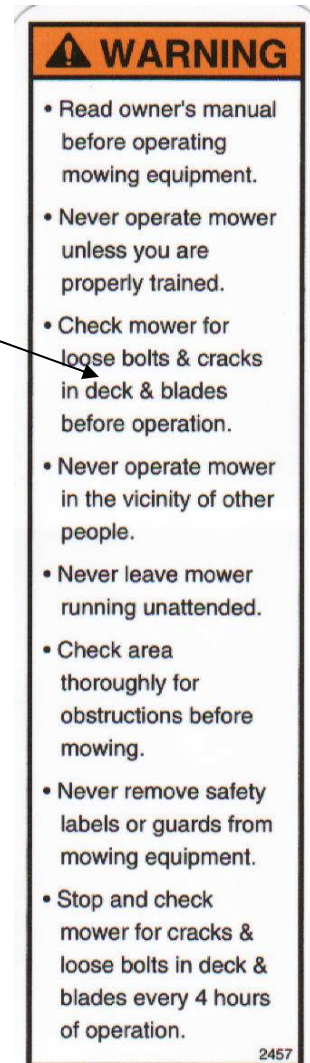

WARNING

- Read owner's manual before operating mowing equipment.
- Never operate mower unless you are properly trained.
- Check mower for loose bolts & cracks in deck & blades before operation.
- Never operate mower in the vicinity of other people.
- Never leave mower running unattended.
- Check area thoroughly for obstructions before mowing.
- Never remove safety labels or guards from mowing equipment.
- Stop and check mower for cracks & loose bolts in deck & blades every 4 hours of operation.

2457

Part # - SW-4



WARNING

Do not remove this guard.

2455B